

## INDEX of SECTION XI: GAS LIFT - KICK OVER TOOLS

PRODUCT DESCRIPTION	Product Code	Page
<b>KICK OVER TOOLS</b>		
		<b>XI-0-9</b>
'ROTK' and 'ROTAK'	195	1
'ROTL' and 'ROTL2-D'	194	1
'ROKOK-5'	192	2,3
'ROKOK-6'	192	4
'ROTOM-1'	191	5-8
'ROTOM-5'	191	8
'ROTR'	193	9

**Gas Lift** operations are efficient and cost efficient means of optimizing the production rates of the wells.

In this Section, **Rebco** presents the **KOT's (Kick-Over Tools)** offered. The **Running** and **Pulling** Tools, as well as some of the **Accessories** required, are listed in Sections, 3 and 4.

Chart: Kick-Over Tools available from **Rebco**

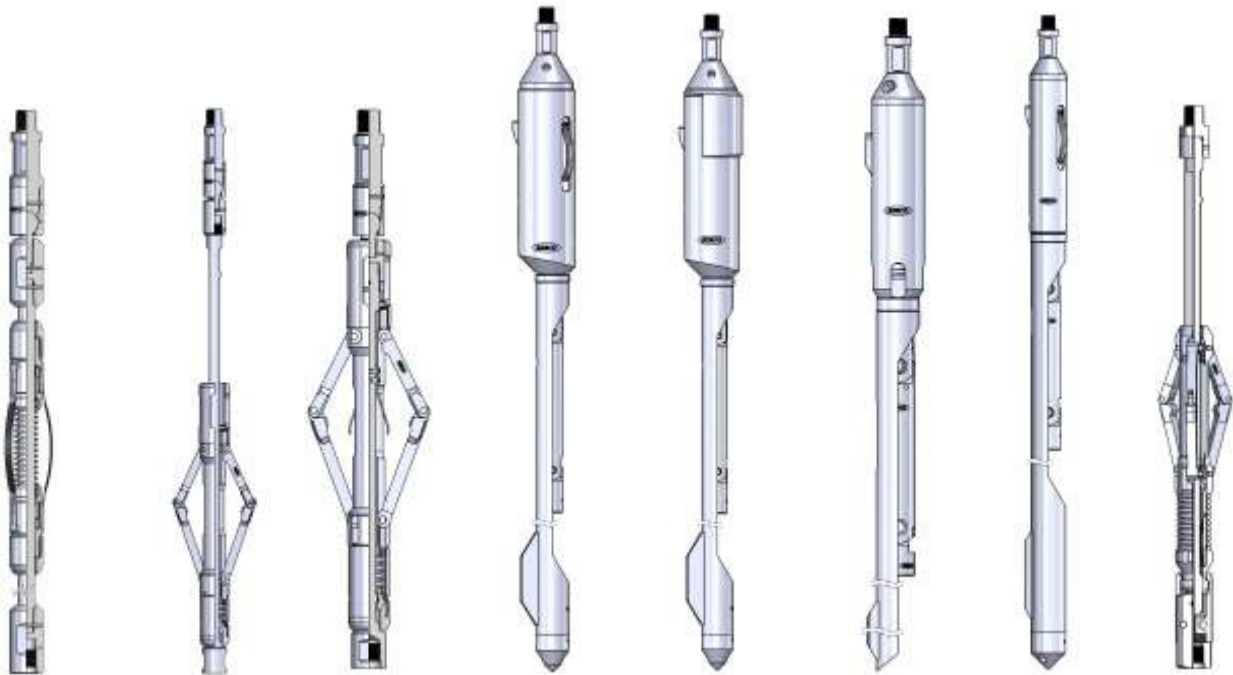

'ROTK' 'ROTAK'    'ROTL'    'ROTL-2D'    'ROKOK-5'    'ROKOK-6'    'ROTOM-1'    'ROTOM-5'    'ROTR'



# SECTION XI: GAS LIFT KICK OVER TOOLS

2021

**REBCO**

**Product Code: 195**

**Type 'ROTK' and 'ROTAK' Kick-Over Tool (KOT) Assembly: 2"- 2 1/2", 3", 1 1/2"**

*Rebco* Type '**ROTK**' KOT is used to install and retrieve 1" OD side pocket sub-surface control devices into Side Pocket Mandrels (SPM).



NOMINAL SIZE	1 1/2"	2" - 2 1/2"	3"
ASSEMBLY NUMBER	19500241500	195242250	195243000
<b>KICK OVER TOOL TYPE</b>	Type ' <b>ROTAK</b> '	Type ' <b>ROTK</b> '	Type ' <b>ROTK</b> '

**ENGINEERING DATA:**

PIN THREAD CONNECTION	15/16" - 10	15/16" - 10	15/16" - 10
FISHING NECK OD	1.187"	1.375"	1.375"
LENGTH	29.37"	29.72"	29.72"
MATERIAL	Alloy	Alloy	Alloy

**Product Code: 194**

**Type 'ROTL' Kick-Over Tool (KOT) Assembly: 2"- 2 1/2"**

*Rebco* Type '**ROTK**' KOT is used to install and retrieve 1" and 1 1/2" OD Sub-surface control devices into Side Pocket Mandrels (SPM).

NOMINAL SIZE	2" - 2 1/2"
ASSEMBLY NUMBER	194082250
<b>KICK OVER TOOL TYPE</b>	Type ' <b>ROTL</b> '

**ENGINEERING DATA:**

PIN THREAD CONNECTION	15/16" - 10
FISHING NECK OD	1.187"
LENGTH	29.94"
MATERIAL	Alloy

'ROTK' Series KOT



Type 'ROTL' KOT

**Product Code: 194**

**Type 'ROTL-2D' Kick-Over Tool (KOT) Assembly: 2"- 2 1/2", 3"**

*Rebco* Type '**ROTL-2D**' KOT is used to install and retrieve 1" and 1 1/2" OD Sub-surface control devices into Side Pocket Mandrels (SPM).

NOMINAL SIZE	2" - 2 1/2"	3"
ASSEMBLY NUMBER	194082032250	194082033000
<b>KICK OVER TOOL TYPE</b>	Type ' <b>ROTL-2D</b> '	Type ' <b>ROTL-2D</b> '

**ENGINEERING DATA:**

PIN THREAD CONNECTION	15/16" - 10	15/16" - 10
FISHING NECK OD	1.187"	1.187"
LENGTH	21"	21"
MATERIAL	Alloy	Alloy

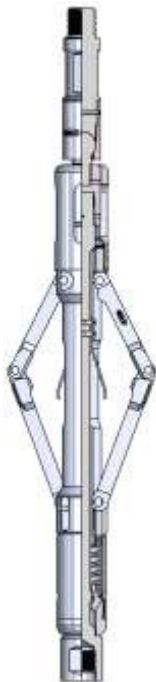

Type 'ROTL-2D' KOT



# SECTION XI: GAS LIFT KICK OVER TOOLS

2021

**REBCO**

**Product Code: 192**

**Type 'ROKOK-5' Kick-Over Tool (KOT) Assembly: 2" – 4 1/2"**

*Rebco* Type 'ROKOK-5' KOT is used to install and retrieve 1" OD side pocket sub-surface control devices into Side Pocket Mandrels (SPM).

Type 'ROKOK-5' Kick-Over Tools have spring type centralizers (DET 11).

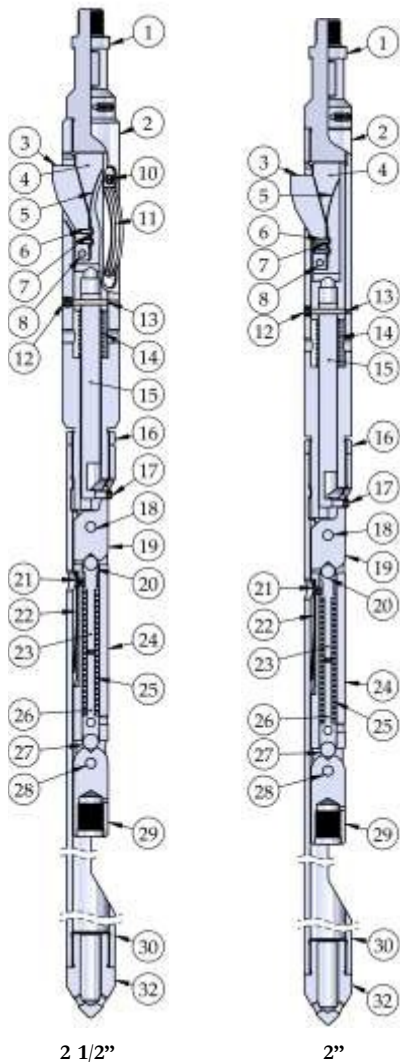

Type 'ROKOK-5' KOT

NOMINAL SIZE	2"	2 1/2"
ASSEMBLY NUMBER	192202452000	192202452500

DET	PART NAME	QTY	PART NO	PART NO
1	FISHING NECK	1		
2	FINGER CAGE	1		
3	LOCATING FINGER	1		
4	FINGER HOUSING	1		
5 *	LEAF SPRING	2		
6 *	BUTTON HEAD SCREW	2		
7 *	LOCK WASHER	2		
8 *	FINGER PIN	1		
10 *	SOCKET BUTTON SCREW	2		
11 *	CENTRALIZER SPRING	2		
12 *	SET SCREW	1		
13 *	SHEAR PIN	1		
14 *	RETURN SPRING	1		
15	RELEASE PLUNGER	1		
16	LOCK RING	1		
17 *	LOCKING SCREW	1		
18 *	ARM PIN – (UPPER)	1		
19	ARM ADAPTER	1		
20 *	BALL	1		
21 *	LOCKING SCREW	1		
22 *	KICK SPRING	2		
23	SPRING INSERT	1		
24	ARM	1		
25 *	DETENT SPRING	1		
26	BALL SEAT	1		
27	BALL	1		
28 *	ARM PIN – (LOWER)	1		
29	LOWER ADAPTER	1		
30	HOUSING	1		
32	NOSE	1		
<b>REDRESS KIT (* Included as part of Kit)</b>				

**ENGINEERING DATA:**

MAXIMUM OD	1.750"	2.063"
Tubing ID required for proper tool orientation	1.945"	2.437"
PIN THREAD CONNECTION	15/16" – 10	15/16" – 10
FISHING NECK OD	1.375"	1.375"
LENGTH	64 7/8"	67.0"
MATERIAL	Alloy	Alloy
WEIGHT lbs (kg)	18.0 (8.2)	18.3 (8.30)

**ACCESSORY:**

<b>Service Tool:</b> Type 'ST' for Detent Spring	<b>5514151</b>
--	----------------



# SECTION XI: GAS LIFT KICK OVER TOOLS

2021

**REBCO**

## Type 'ROKOK-5' Kick-Over Tool (KOT) Assembly: Continued

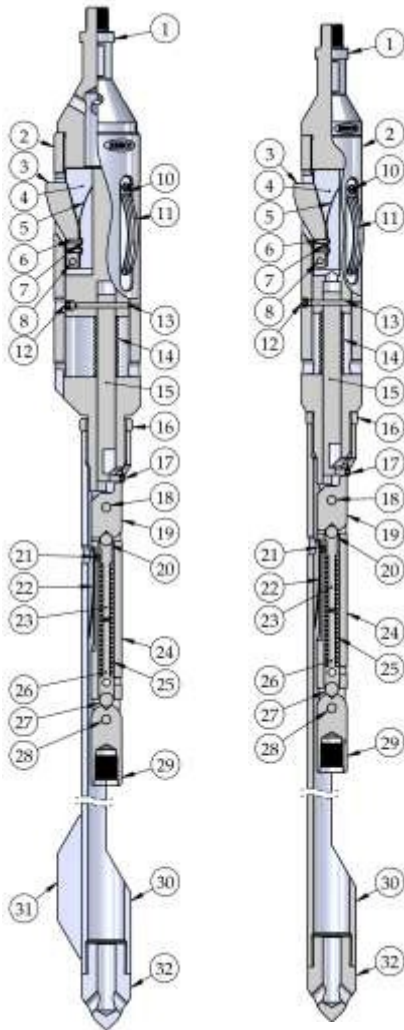

4 1/2"

3"

Type 'ROKOK-5' KOT

NOMINAL SIZE	3"	4 1/2"
ASSEMBLY NUMBER	192202453000	192202454500

DET	PART NAME	QTY	PART NO	PART NO
1	FISHING NECK	1		
2	FINGER CAGE	1		
3	LOCATING FINGER	1		
4	FINGER HOUSING	1		
5 *	LEAF SPRING	2		
6 *	BUTTON HEAD SCREW	2		
7 *	LOCK WASHER	2		
8 *	FINGER PIN	1		
10 *	SOCKET BUTTON SCREW	2		
11 *	CENTRALIZER SPRING	2		
12 *	SET SCREW	1		
13 *	SHEAR PIN	1		
14 *	RETURN SPRING	1		
15	RELEASE PLUNGER	1		
16	LOCK RING	1		
17 *	LOCKING SCREW	1		
18 *	ARM PIN – (UPPER)	1		
19	ARM ADAPTER	1		
20 *	BALL	1		
21 *	LOCKING SCREW	1		
22 *	KICK SPRING	2		
23	SPRING INSERT	1		
24	ARM	1		
25 *	DETENT SPRING	1		
26	BALL SEAT	1		
27	BALL	1		
28 *	ARM PIN – (LOWER)	1		
29	LOWER ADAPTER	1		
30	HOUSING	1		
31	SKATE	1		
32	NOSE	1		
<b>30/31</b>	<b>Housing Sub-Assembly</b>	<b>REF</b>		
<b>REDRESS KIT (* Included as part of Kit)</b>				

**ENGINEERING DATA:**

MAXIMUM OD	2.500"	3.500"
Tubing ID required for proper tool orientation	2.921"	3.958"
PIN THREAD CONNECTION	15/16" – 10	15/16" – 10
FISHING NECK OD	1.375"	1.375"
LENGTH	71 1/8"	71 7/8"
MATERIAL	Alloy	Alloy
WEIGHT lbs (kg)	22.0 (9.98)	48.0 (21.7)

**ACCESSORY:**

<b>Service Tool:</b> Type 'ST' for Detent Spring	<b>5514151</b>
--	----------------



# SECTION XI: GAS LIFT KICK OVER TOOLS

2021

**REBCO**

**Product Code: 192**

**Type 'ROKOK-6' Kick-Over Tool (KOT) Assembly: 2 1/2" – 4 1/2"**

*Rebco* Type 'ROKOK-6' KOT is used to install and retrieve 1" OD side pocket sub-surface control devices into Side Pocket Mandrels (SPM).

Type 'ROKOK-6' Kick-Over Tools have sleeve type centralizer (DET 11).

NOMINAL SIZE	2 7/8"	3"	4 1/2"
ASSEMBLY NUMBER	192202462500	192202463000	192202464500

DET	PART NAME	QTY	PART NO	PART NO	PART NO
1	FISHING NECK	1			
2	FINGER CAGE	1			
3	LOCATING FINGER	1			
4	FINGER HOUSING	1			
5 *	LEAF SPRING	2			
6 *	BUTTON HEAD SCREW	2			
7 *	LOCK WASHER	2			
8 *	FINGER PIN	1			
9 *	SET SCREW	1			
11	CENTRALIZER SLEEVE	1			
12 *	SET SCREW	1			
13 *	SHEAR PIN	1			
14 *	RETURN SPRING	1			
15	RELEASE PLUNGER	1			
16	LOCK RING	1			
17 *	LOCKING SCREW	1			
18 *	ARM PIN – (UPPER)	1			
19	ARM ADAPTER	1			
20 *	BALL	1			
21 *	LOCKING SCREW	1			
22 *	KICK SPRING	2			
23	SPRING INSERT	1			
24	ARM	1			
25 *	DETENT SPRING	1			
26	BALL SEAT (Sub-Ass'y)	1			
27	BALL (Reference)	1			
28	ARM PIN – (LOWER)	1			
29	LOWER ADAPTER	1			
<b>30 - 31</b>	<b>HOUSING SUB-ASS'Y</b>	<b>1</b>	-		
30	HOUSING	1			
31	SKATE	1	(none)		
32	NOSE	1			
<b>REDRESS KIT (* Included as part of Kit)</b>					

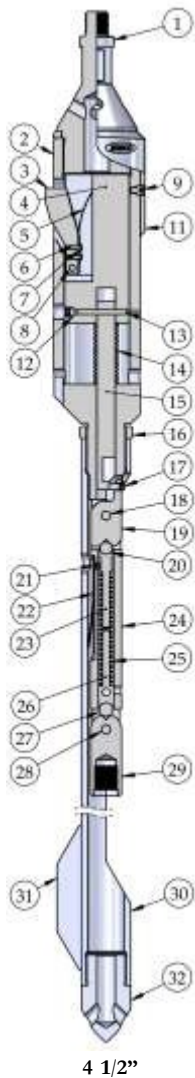

4 1/2"

Type 'ROKOK-6' KOT

**ENGINEERING DATA:**

MAXIMUM OD	2.223"	2.500"	3.500"
Tubing ID required for proper tool orientation	2.437"	2.921"	3.958"
PIN THREAD CONNECTION	15/16" – 10	15/16" – 10	15/16" – 10
FISHING NECK OD	1.375"	1.375"	1.375"
LENGTH	67.0"	71.125"	71.87"
MATERIAL	Alloy	Alloy	Alloy
WEIGHT lbs (kg)	26.3 (11.9)	34.7 (15.7)	48.5 (21.9)

**ACCESSORY:**

Service Tool: Type 'ST' for Detent Spring	<b>5514151</b>
---	----------------



# SECTION XI: GAS LIFT KICK OVER TOOLS

2021

**REBCO**

**Product Code: 191**

**Type 'ROTOM-1' Kick-Over Tool (KOT) Assembly: 2" – 7"**

*Rebco* Type '**ROTOM-1**' KOT is used to install and retrieve 1 1/2" OD side pocket sub-surface control devices into Side Pocket Mandrels (SPM).

**NOTE:** Type '**ROTOM-1**' Kick-Over Tools are available (**Variation**) with or without **Catcher Sub-Assembly (DET 29-31)**, when ordering, please specify.

NOMINAL SIZE	2"	2 1/2"	3"
ASSEMBLY NUMBER	191200912000	191200912500	191200913000

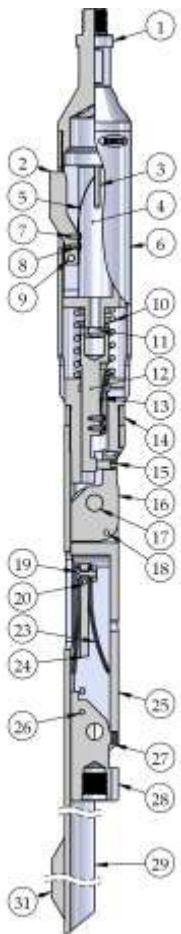

DET	PART NAME	QTY	PART NO	PART NO	PART NO
1	FISHING NECK	1			
2	LOCATING FINGER	1			
3	SPRING BASE	1			
4	FINGER HOUSING	1			
5 *	LEAF SPRING	2			
6	FINGER CAGE	1			
7 *	BUTTON HEAD SCREW	2			
8 *	LOCK WASHER	2			
9 *	FINGER PIN	1			
10	RETURN SPRING	1			
11 *	SHEAR PIN	1			
12	RELEASE PLUNGER	1			
13	RELEASE SPRING	1			
14	LOCK RING	1			
15 *	LOCKING SCREW	1			
16	ARM ADAPTER	1			
17	ARM PIN	2			
18 *	SHEAR PIN	1			
19 *	CAP SCREW	1			
20 *	SHEAR PIN	1			
21 *	SET SCREW	1			
23 *	KICK SPRING	Noted	(2)	(2)	(2)
24	SPRING HINGE	1			
25	ARM	1			
26	SHEAR PIN	1			
27	SET SCREW	1			
28	LOWER ADAPTER	1			
29	HOUSING	1			
<b>REDRESS KIT (* Included as part of Kit)</b>					

**ENGINEERING DATA:**

<b>VARIATION Available, See Note</b>			<b>YES Note</b>
MAXIMUM OD	1.859"	2.223"	2.739"
PIN THREAD CONNECTION	15/16" – 10	15/16" – 10	15/16" – 10
FISHING NECK OD	1.375"	1.375"	1.375"
LENGTH	88.687"	81.750"	81.875"
MATERIAL	Alloy	Alloy	Alloy
WEIGHT lbs (kg)	18.1 (8.21)	18.4 (8.35)	37.7 (17.1)

**ACCESSORY:**

<b>SPACER BAR - (1 1/2" x 11 1/4")</b>	<b>5500819</b>	<b>5500819</b>	<b>5500819</b>
--	----------------	----------------	----------------

**Note: 3" Type 'ROTOM-1' - Assembly Number 191200913001 - is with Valve Catcher**



# SECTION XI: GAS LIFT KICK OVER TOOLS

2021

REBCO

## Type 'ROTOM-1' Kick-Over Tool (KOT) Assembly: Continued

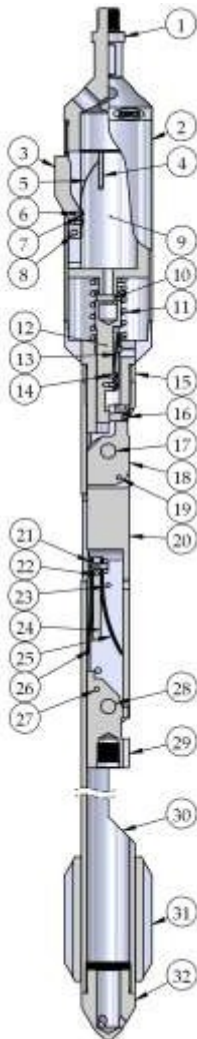

NOMINAL SIZE	4"
ASSEMBLY NUMBER	191200914500

DET	PART NAME	QTY	PART NO
1	FISHING NECK	1	
2	FINGER CAGE	1	
3	LOCATING FINGER	1	
4	SPRING BASE	1	
5 *	LEAF SPRING	2	
6 *	BUTTON HEAD SCREW	2	
7 *	LOCK WASHER	2	
8 *	FINGER PIN	1	
9	FINGER HOUSING	1	
10 *	SHEAR PIN	1	
11	CORE SPRING	1	
12	RELEASE PLUNGER	1	
13 *	RELEASE SPRING	1	
14 *	SCREW	2	
	LOCK WASHER	2	
15	LOCK RING	1	
16 *	LOCKING SCREW	1	
17	UPPER ARM PIN	1	
18	ARM ADAPTER	1	
19 *	SHEAR PIN	1	
20	ARM	1	
21 *	CAP SCREW	1	
22 *	SHEAR PIN	1	
23 *	SHEAR PIN	1	
24	SPRING HINGE	1	
25	KICK SPRING	2	
26	INTERNAL KICK SPRING	3	
27	SHEAR PIN	1	
28	LOWER ARM PIN	1	
29	LOWER ADAPTER	1	
<b>SUB-ASSEMBLY (DET 30 - 32)</b>			<b>19120091450</b>
30	HOUSING	1	
31	SKATE (Sleeve)	1	
32	NOSE	1	
<b>REDRESS KIT</b> (* Included as part of Kit)			

### ENGINEERING DATA:

MAXIMUM OD	3.723"
PIN THREAD CONNECTION	15/16" – 10
FISHING NECK OD	1.375"
LENGTH	81.75"
MATERIAL	Alloy
WEIGHT lbs (kg)	55.5 (25.17)

### ACCESSORY:

SPACER BAR - (1 1/2" x 11 1/4")	5500819
---------------------------------	---------



# SECTION XI: GAS LIFT KICK OVER TOOLS

2021

**REBCO**

## Type 'ROTOM-1' Kick-Over Tool (KOT) Assembly: Continued

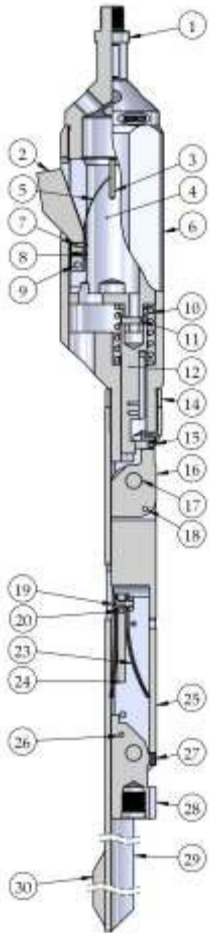

NOMINAL SIZE	5"	5" NOTE
ASSEMBLY NUMBER	191200915000	191200915001

DET	PART NAME	QTY	PART NO	PART NO
1	FISHING NECK	1		
2	LOCATING FINGER	1		
3	SPRING BASE	1		
4	FINGER HOUSING	1		
5 *	LEAF SPRING	2		
6	FINGER CAGE	1		
7 *	BUTTON HEAD SCREW	2		
8 *	LOCK WASHER	2		
9 *	FINGER PIN	1		
10	RETURN SPRING	1		
11 *	SHEAR PIN	1		
12	RELEASE PLUNGER	1		
14	LOCK RING	1		
15 *	LOCKING SCREW	1		
16	ARM ADAPTER	1		
17	ARM PIN	2		
18 *	SHEAR PIN	1		
19 *	CAP SCREW	1		
20 *	SHEAR PIN	1		
21 *	SET SCREW	1		
23 *	KICK SPRING	Noted		
24	SPRING HINGE	1		
25	ARM	1		
26	SHEAR PIN	1		
27	SET SCREW	1		
28	LOWER ADAPTER	1		
29	HOUSING	1		
30	SKATE	1		
<b>REDRESS KIT (* Included as part of Kit)</b>				

**ENGINEERING DATA:**

MAXIMUM OD	4.068"	3.920"
PIN THREAD CONNECTION	15/16" – 10	15/16" – 10
FISHING NECK OD	1.375"	1.375"
LENGTH	82.187"	82.187"
MATERIAL	Alloy	Alloy
WEIGHT lbs (kg)	50.0 (22.68)	49.0 (22.23)

**ACCESSORY:**

SPACER BAR - (1 1/2" x 11 1/4")	5500819	5500819
---------------------------------	---------	---------

**Note:** Assembly No 191200915001 is Special OD to pass through 4.125" SSSV





# SECTION XI: GAS LIFT KICK OVER TOOLS

2021

**REBCO**

## Type '**ROTOM-1**' Kick-Over Tool (KOT) Assembly: Continued

NOMINAL SIZE	5 1/2"
ASSEMBLY NUMBER	191200915500

**ENGINEERING DATA:**

MAXIMUM OD	4.250"
PIN THREAD CONNECTION	1 9/16" – 10
FISHING NECK OD	2.313"
LENGTH	78.125"
MATERIAL	Alloy
WEIGHT lbs (kg)	97.5 (44.23)

**ACCESSORY:**

SPACER BAR	5500819
------------	---------

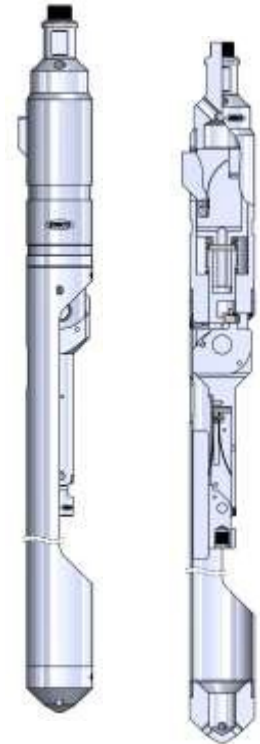

Product Code: 191

## Type '**ROTOM-5**' Kick-Over Tool (KOT) Assembly: 3 1/2"

**Rebco** Type '**ROTOM-5**' KOT is used to install and retrieve 1 1/2" OD side pocket sub-surface control devices into Side Pocket Mandrels (SPM).

Type '**ROTOM-5**' KOT uses a ball detent and detent spring design to ease redress procedure in the field.



NOMINAL SIZE	2 1/2"	3 1/2"
ASSEMBLY NUMBER	191200952500	191200953500

**ENGINEERING DATA:**

MAXIMUM OD (Centralizing Retracted)	2.250"	2.531"
PIN THREAD CONNECTION	15/16" – 10	15/16" – 10
FISHING NECK OD	1.375"	1.375"
LENGTH	93.812"	93.812"
MATERIAL	Alloy	Alloy
WEIGHT lbs (kg)	19.6 (8.9)	25.0 (11.3)

**ACCESSORY:**

SPACER BAR - (1 1/2" x 11 1/4")	5500819	5500819
---------------------------------	---------	---------



# SECTION XI: GAS LIFT KICK OVER TOOLS

2021



**Product Code: 193**

**Type 'ROTR' Kick-Over Tool (KOT) Assembly: 2" - 2 1/2" and 3 1/2"**



*Rebco* Type '**ROTR**' KOT is used to install and retrieve **1 1/2" OD** side pocket sub-surface control devices into Side Pocket Mandrels (**SPM**).

NOMINAL SIZE	2"	2 1/2"	3 1/2"
ASSEMBLY NUMBER	19313202000	19313202500	19313203000

**ENGINEERING DATA:**

MAXIMUM OD - Arms Retracted	1.859"	2.281"	2.500"
MAXIMUM OD - Arms Open	3.813"	3.813"	5.688"
PIN THREAD CONNECTION	15/16" - 10	15/16" - 10	15/16" - 10
BOX THREAD CONNECTION	15/16" - 10	15/16" - 10	15/16" - 10
LENGTH	27 1/8"	27 1/8"	30 1/2"
MATERIAL	Alloy	Alloy	Alloy